

## SkyLine Chills Blast Chiller-Freezer 10GN1/1 50/50 kg, right hinged door

ITEM # \_\_\_\_\_

MODEL # \_\_\_\_\_

NAME # \_\_\_\_\_

SIS # \_\_\_\_\_

AIA # \_\_\_\_\_

**727907 (EBFA11HE)**

Skyline Chills Blast Chiller Freezer 50/50kg, 10 GN 1/1 or 600x400mm (29 levels pitch 30mm) with touch screen control and right hinged door

### Short Form Specification

#### Item No.

- Blast chiller freezer with high resolution full touch screen interface, multilanguage.
- For 10 GN 1/1 or 600x400 mm trays. Up to 14 ice cream basins (360x250x80h mm).
- Load capacity: chilling 50 kg; freezing 50 kg.
- OptiFlow air distribution system to achieve maximum performance with 7 fan speed levels.
- Chilling/Freezing modes: Automatic (10 food families with 100+ different pre-installed variants); Programs (a maximum 1000 programs can be stored and organized in 16 different categories); Manual (soft chilling, hard chilling, freezing, holding, turbo cooling and lite hot cycles); Specialistic Cycles (Cruise chilling, proving, retarded proving, fast thawing, Sushi&Sashimi, Sous-Vide chilling, ice-cream, yogurt and chocolate).
- Special functions: MultiTimer chilling/freezing, Make-it-Mine to customize interface, SkyHub to customize homepage, agenda MyPlanner, SkyDuo connection to SkyLine ovens.
- Remaining time estimation for probe-driven cycles based on artificial intelligence techniques (ARTE 2.0).
- Automatic and manual defrosting and drying.
- USB port to download HACCP data, programs and settings. Connectivity ready.
- 3-point multi sensor core temperature probe.
- Stainless steel construction throughout.
- Internal rounded corners.
- Built-in refrigeration unit.
- R452a refrigerant gas.
- Performance guaranteed at ambient temperatures of +43°C (Climatic class 5).

### Main Features

- Blast Chilling cycle: 50 kg from +90°C up to +3°C.
- X-Freeze cycle: ideal for blast freezing all kinds of food (raw, half or fully cooked).
- Lite-Hot cycle: ideal for soft heating preparations.
- Holding at +3 °C for chilling or -22 °C for freezing, automatically activated at the end of each cycle, to save energy and maintain the target temperature (manual activation is also possible).
- Turbo cooling: chiller works continuously at the desired temperature; ideal for continuous production.
- Automatic mode including 10 food families (meat, poultry, fish, sauces and soup, vegetables, pasta/ rice, bread, savory and sweet bakery, dessert, beverage fast cooling) with 100+ different pre-installed variants. Through Automatic Sensing Phase the blast chiller optimizes the chilling process according to size, quantity and type of food loaded to achieve the selected result. Real time overview of the chilling parameters. Possibility to personalize and save up to 70 variants per family.
- Cycles+:
  - Cruise Cycle (Patented EP1716769B1 and related family) automatically sets the parameters for the quickest and best chilling (it works with probe)
  - Proving
  - Delayed Proving
  - Fast Thawing
  - Sushi&Sashimi (anisakis-free food)
  - Chill Sous-vide
  - Ice Cream
  - Yogurt
  - Chocolate
- Programs mode: a maximum of 1000 programs can be stored in the blast chiller's memory, to recreate the exact same high standard at any time. The programs can be grouped in 16 different categories to better organize the menu. 16-step chilling programs also available.
- MultiTimer function to manage up to 20 different chilling cycles at the same time, improving flexibility and ensuring excellent results. Can be saved up to 200 MultiTimer programs.
- OptiFlow air distribution system to achieve maximum performance in chilling/heating evenness and temperature control thanks to a special design of the chamber combined with high precision variable speed fan.
- Fan with 7 speed levels. Fan stops in less than 5 seconds when door is opened.
- 3-point multi sensor core temperature probe for high precision and food safety.
- Remaining time estimation for probe-driven cycles based on artificial intelligence techniques (ARTE 2.0 Patented US7971450B2 and related family) for an easier planning of the activities.
- Customizable pre-cooling and pre-heating functions.
- Automatic and manual defrosting and drying.
- Performance guaranteed at ambient temperatures of +43°C (Climatic class 5).
- Freezing cycle: 50 kg from 90°C up to -41°C.

**APPROVAL:** \_\_\_\_\_

- Multi-purpose internal structure suitable for gastronomy, bakery trays or ice-cream basins.

### Construction

- Built-in refrigeration unit.
- Solenoid valve to automatically manage the gas pressure in the thermodynamic circuit.
- Main components in 304 AISI stainless steel.
- Evaporator with antirust protection.
- Motors and fan waterproof protected IP54.
- Hygienic internal chamber with all rounded corners for easy cleaning.
- Removable magnetic gasket door with hygienic design.
- Ventilator swinging hinged panel for access to the evaporator for cleaning.
- Door stopper to keep the door open in order to avoid the formation of bad smells (kit available to be mounted on site, depending on preferred door hinge).
- Automatic heated door frame.

### User Interface & Data Management

- High resolution full touch screen interface (translated in more than 30 languages) - color-blind friendly panel.
- Pictures upload for full customization of cycles.
- Make-it-mine feature to allow full personalization or locking of the user interface.
- SkyHub lets the user group the favorite functions in the homepage for immediate access.
- MyPlanner works as an agenda where the user can plan the daily work and receive personalized alerts for each task.
- With SkyDuo the Oven and the Blast Chiller are connected to each other and communicate in order to guide the user through the cook&chill process optimizing time and efficiency (requires optional accessory).
- USB port to download HACCP data, share chilling programs and configurations.
- Connectivity ready for real time access to connected appliances from remote and HACCP monitoring (requires optional accessory).
- Trainings and guidances supporting materials easily accessible by scanning QR-Code with any mobile device.
- Automatic consumption visualization at the end of the cycle.

### Sustainability



- Human centered design with 4-star certification for ergonomics and usability.
- Zero Waste provides chefs with useful tips for minimizing food waste.  
Zero Waste is a library of Automatic recipes that aims to:
  - give a second life to raw food close to expiration date (e.g.: from milk to yogurt)
  - obtain genuine and tasty dishes from overripe fruit/vegetables (usually considered not appropriate for sale)
  - promote the use of typically discarded food items (e.g.: carrot peels).

### Included Accessories

- 1 of 3-sensor probe for blast chiller freezer PNC 880582

Front

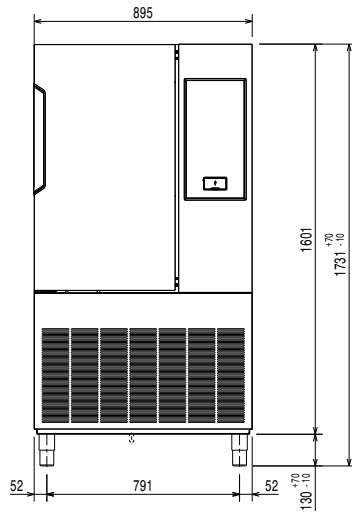

Side

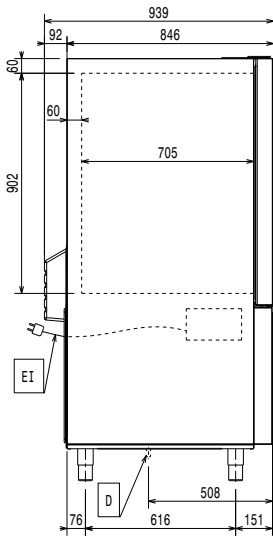

D = Drain  
EI = Electrical inlet (power)

Top

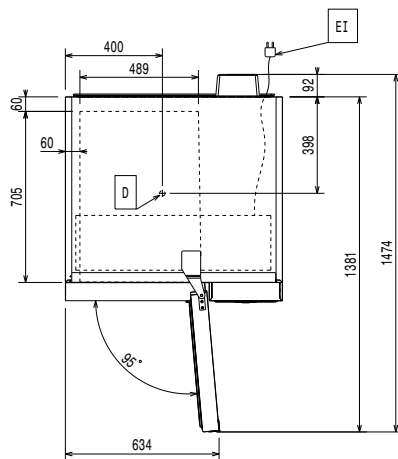

## Electric

Circuit breaker required

**Supply voltage:** 380-415 V/3N ph/50 Hz

**Electrical power, max:** 4.15 kW

**Heating power:** 1.9 kW

## Water:

**Drain line size:** 1"1/2

## Installation:

**Clearance:** 5 cm on sides and back.

Please see and follow detailed installation instructions provided with the unit

## Capacity:

**Max load capacity:** 50 kg

**Number and type of grids:** 10 (GN 1/1; 600x400)

**Number and type of basins:** 14 (360x250x80h)

## Key Information:

**Door hinges:** Right Side

**External dimensions, Width:** 895 mm

**External dimensions, Depth:** 939 mm

**External dimensions, Height:** 1731 mm

**Net weight:** 227 kg

**Shipping weight:** 240 kg

**Shipping volume:** 1.96 m<sup>3</sup>

## Refrigeration Data

Built-in Compressor and Refrigeration Unit

**Refrigeration power at evaporation temperature:** -20 °C

**Condenser cooling type:** AIR

## Product Information (EN17032 - Commission Regulation EU 2015/1095)

Test performed in a test room at 30°C to chill/ freeze (+10°C/-18° C) a full load of 40mm deep trays filled with mashed potatoes evenly distributed up to a height of 35 mm at starting temperature between 65° and 80°C within 120/270min.

**Chilling Cycle Time (+65°C to +10°C):** 69 min

**Full load capacity (chilling):** 50 kg

**Freezing Cycle Time (+65°C to -18°C):** 245 min

**Full load capacity (freezing):** 50 kg

## ISO Certificates

**ISO Standards:** ISO 9001; ISO 14001; ISO 45001; ISO 50001

## Sustainability

**Refrigerant type:** R452A

**GWP Index:** 2141

**Refrigeration power:** 4220 W

**Refrigerant weight:** 2000 g

**Energy consumption, cycle (chilling):** 0.0798 kWh/kg

**Energy consumption, cycle (freezing):** 0.2253 kWh/kg

SkyLine Chills  
Blast Chiller-Freezer 10GN1/1 50/50 kg, right hinged door

The company reserves the right to make modifications to the products without prior notice. All information correct at time of printing.